

DYNAMIC ENGINEERING

435 Park Dr., Ben Lomond, Calif. 95005
831-336-8891 Fax 831-336-3840
sales@dyneng.com
www.dyneng.com
Est. 1988

User Manual

PMC-BiSerial-III HW1

32 channel
Bi-directional Manchester Interface
PMC Module

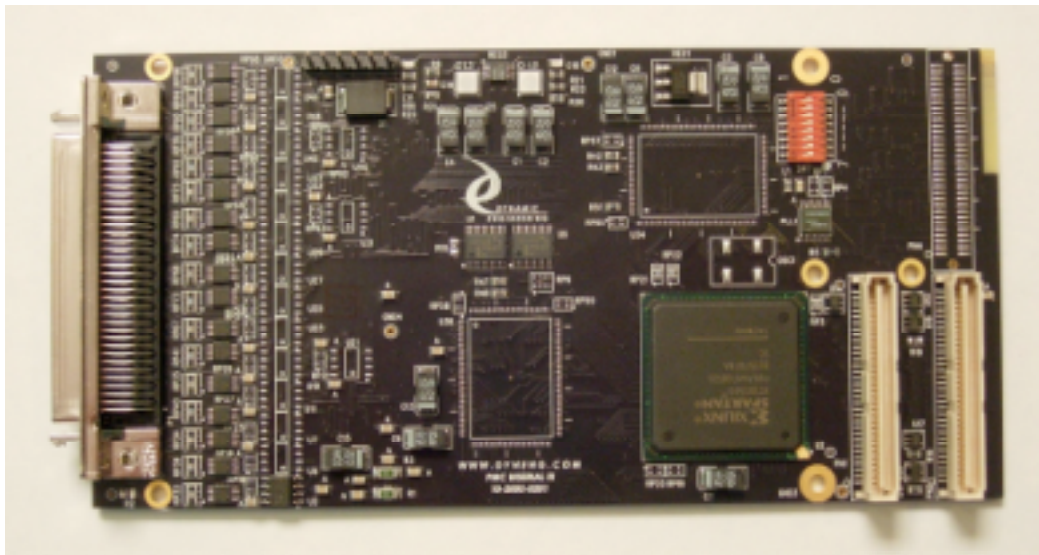

Revision A2
Corresponding Hardware: Revision A/B
10-2005-0501/2

PMC-BiSerial-III HW1
Bi-Directional Serial Data
Interface
PMC Module

Dynamic Engineering
435 Park Drive
Ben Lomond, CA 95005
831-336-8891
831-336-3840 FAX

This document contains information of proprietary interest to Dynamic Engineering. It has been supplied in confidence and the recipient, by accepting this material, agrees that the subject matter will not be copied or reproduced, in whole or in part, nor its contents revealed in any manner or to any person except to meet the purpose for which it was delivered.

Dynamic Engineering has made every effort to ensure that this manual is accurate and complete. Still, the company reserves the right to make improvements or changes in the product described in this document at any time and without notice. Furthermore, Dynamic Engineering assumes no liability arising out of the application or use of the device described herein.

The electronic equipment described herein generates, uses, and can radiate radio frequency energy. Operation of this equipment in a residential area is likely to cause radio interference, in which case the user, at his own expense, will be required to take whatever measures may be required to correct the interference.

Dynamic Engineering's products are not authorized for use as critical components in life support devices or systems without the express written approval of the president of Dynamic Engineering.

This product has been designed to operate with PMC Module carriers and compatible user-provided equipment. Connection of incompatible hardware is likely to cause serious damage.

©2005 by Dynamic Engineering.

Other trademarks and registered trademarks are owned by their respective manufactures.
Revised November 5, 2005.



Table of Contents

PRODUCT DESCRIPTION	6
THEORY OF OPERATION	9
ADDRESS MAP	11
PROGRAMMING	14
REGISTER DEFINITIONS	15
BIS3_BASE	15
BIS3_ID	16
BIS3_START_SET	16
BIS3_START_RDBK	16
BIS3_START_CLR	17
BIS3_IO_DATA	18
BIS3_IO_DIR	18
BIS3_IO_TERM	19
BIS3_IO_MUX	19
BIS3_IO_UCNTL	20
BIS3_IO_RDBK	20
BIS3_IO_RDBKUPR	21
BIS3_STAT_FIFO	21
BIS3_PLL	22
BIS3_SM_CNTL31-0	23
BIS3_INT_STAT	26
BIS3_I2OAR	26
BIS3_SM_MEM31-0	27
Interrupts	32
Loop-back	33
PMC PCI PN1 INTERFACE PIN ASSIGNMENT	34
PMC PCI PN2 INTERFACE PIN ASSIGNMENT	35
BISERIAL III FRONT PANEL IO PIN ASSIGNMENT	36



APPLICATIONS GUIDE	37
Interfacing	37
CONSTRUCTION AND RELIABILITY	38
THERMAL CONSIDERATIONS	38
WARRANTY AND REPAIR	39
SERVICE POLICY	39
OUT OF WARRANTY REPAIRS	39
FOR SERVICE CONTACT:	39
SPECIFICATIONS	40
ORDER INFORMATION	41
SCHEMATICS	41



List of Figures

FIGURE 1	PMC BISERIAL-III BASE BLOCK DIAGRAM	6
FIGURE 2	PMC BISERIAL-III-HW1 BLOCK DIAGRAM	7
FIGURE 3	PMC BISERIAL III HW1 MANCHESTER TIMING DIAGRAM	10
FIGURE 4	PMC BISERIAL-III-HW1 INTERNAL ADDRESS MAP	12
FIGURE 5	PMC BISERIAL-III BASE CONTROL REGISTER BIT MAP	15
FIGURE 6	PMC BISERIAL-III INTERRUPT ENABLE REGISTER BIT MAP	16
FIGURE 7	PMC BISERIAL-III START SET REGISTER	16
FIGURE 8	PMC BISERIAL-III START CLEAR REGISTER	17
FIGURE 9	PMC BISERIAL-III PARALLEL OUTPUT DATA BIT MAP	18
FIGURE 10	PMC BISERIAL-III DIRECTION CONTROL PORT	18
FIGURE 11	PMC BISERIAL-III TERMINATION CONTROL PORT	19
FIGURE 12	PMC BISERIAL-III MUX CONTROL PORT	19
FIGURE 13	PMC BISERIAL-III UPPER CONTROL PORT	20
FIGURE 14	PMC BISERIAL-III IO READBACK PORT	20
FIGURE 15	PMC BISERIAL-III IO READBACK PORT	21
FIGURE 16	PMC BISERIAL-III FIFO STATUS	21
FIGURE 17	PMC BISERIAL-III PLL CONTROL	22
FIGURE 18	PMC BISERIAL-III STATE MACHINE CONTROL REGISTERS	23
FIGURE 19	PMC BISERIAL-III INTERRUPT STATUS REGISTER	26
FIGURE 20	PMC BISERIAL-III I2O ADDRESS REGISTER	26
FIGURE 21	PMC BISERIAL-III PN1 INTERFACE	34
FIGURE 22	PMC BISERIAL-III PN2 INTERFACE	35
FIGURE 23	PMC BISERIAL-III FRONT PANEL INTERFACE	36

Product Description

The PMC BiSerial-III-HW1 is part of the PMC Module family of modular I/O components by Dynamic Engineering. The PMC BiSerial-III is capable of providing multiple serial protocols. The HW1 protocol implemented provides 32 Manchester encoded inputs and outputs.

Other custom interfaces are available. We will redesign the state machines and create a custom interface protocol. That protocol will then be offered as a "standard" special order product. Please see our web page for current protocols offered. Please contact Dynamic Engineering with your custom application.

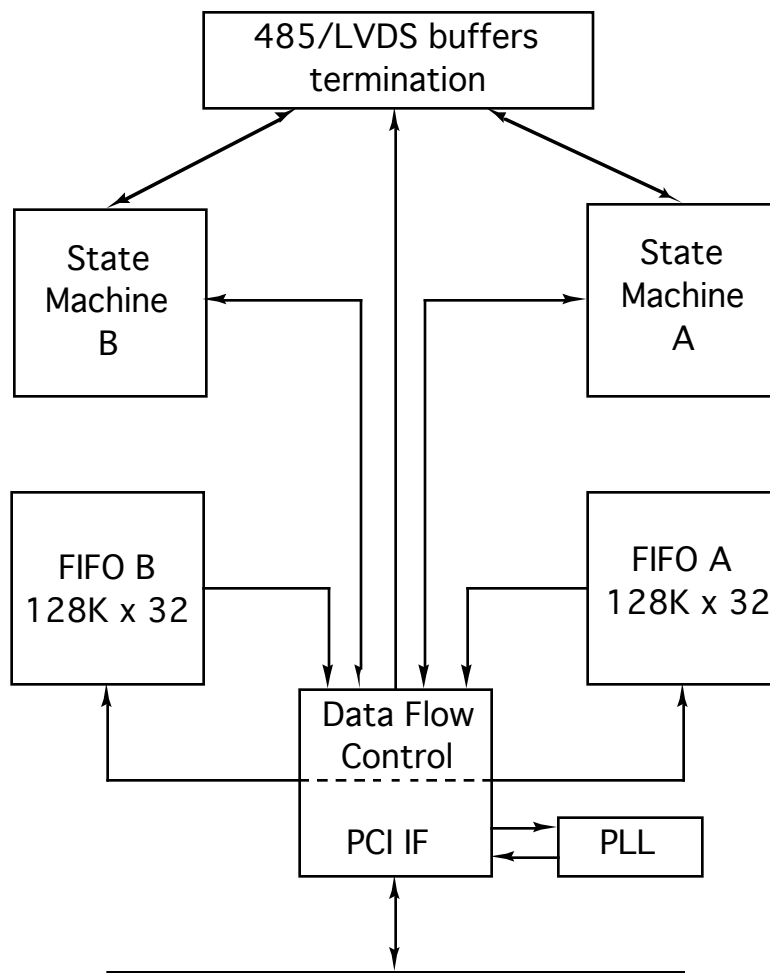

FIGURE 1

PMC BISERIAL-III BASE BLOCK DIAGRAM

The standard configuration shown in Figure one makes use of two external [to the Xilinx] FIFOs. The FIFOs can be as large as 128K deep x 32 bits wide. Some designs do not require so much memory, and are more efficiently implemented using the internal FIFOs.

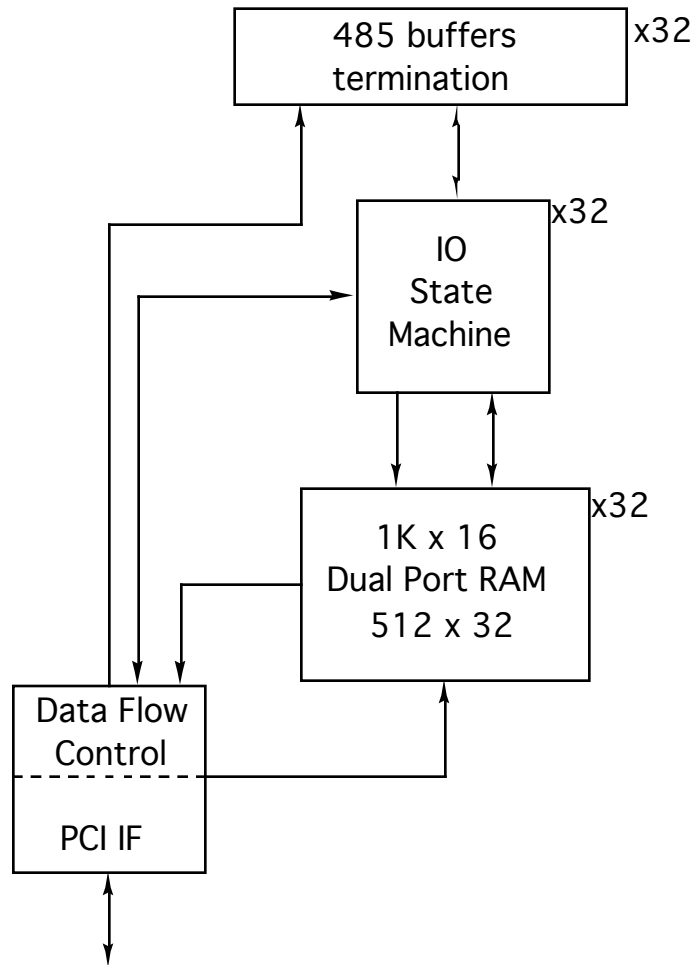

FIGURE 2 PMC BISERIAL-III-HW1 BLOCK DIAGRAM

The HW1 implementation has 32 – Dual Port RAMs using the internal block RAM of the Xilinx. Each channel has an associated DPR. Each DPR is configured to have a 32 bit port on the PCI side, and a 16 bit port on the IO side. When operating in the half duplex mode the DPR is split in half to provide both a transmit, and a receive section. In the uni-directional mode the full DPR can be used for transmit or receive data.

The data rate is programmable. The base rates are 400 KHz and 5 Mhz. Usually the 5 Mhz rate is used with the uni-directional mode and the 400 KHz in the half duplex mode. The PLL can be selected for user defined frequencies.

The data is Manchester encoded. The hardware uses a higher rate clock to separate the clock and data embedded within the Manchester data stream. The data IO within the FPGA are programmable to be register controlled or state-machine controlled. Any or all of the bits can be used as a parallel port.

Thirty-four differential I/O are provided at the front bezel [32 of the 34 at Pn4] for the serial signals. The drivers and receivers conform to the RS-485 specification (exceeds RS-422 specification). The RS-485 input signals are selectively terminated with 100Ω. The termination resistors are in two-element packages to allow flexible termination options for custom formats and protocols. Optional pullup/pulldown resistor packs can also be installed to provide a logic '1' on undriven lines. The terminations and transceivers are programmable through the Xilinx device to provide the proper mix of outputs and inputs and terminations needed for a specific protocol implementation. The terminations are programmable for all IO.

All configuration registers support read and write operations for maximum software convenience, and all addresses are long word aligned.

The PMC BiSerial-III conforms to the PMC and CMC draft standards. This guarantees compatibility with multiple PMC Carrier boards. Because the PMC may be mounted on different form factors, while maintaining plug and software compatibility, system prototyping may be done on one PMC Carrier board, with final system implementation on a different one.

The PMC BiSerial-III uses a 10 mm inter-board spacing for the front panel, standoffs, and PMC connectors. The 10 mm height is the "standard" height and will work in most systems with most carriers. If your carrier has non-standard connectors [height] to mate with the PMC BiSerial-II, please let us know. We may be able to do a special build with a different height connector to compensate.

Interrupts are supported by the PMC BiSerial-III-HW1. An interrupt can be configured to occur at the end of a transmitted packet or message. An interrupt can will be set at the end of a received packet. All interrupts are individually maskable, and a master interrupt enable is also provided to disable all interrupts simultaneously. The current status is available for the state-machines making it possible to operate in a polled mode. 120 interrupt processing is also available.



Theory of Operation

The PMC BiSerial-III-HW1 is designed for transferring data from one point to another with a simple serial protocol.

The PMC BiSerial-III-HW1 features a Xilinx FPGA. The FPGA contains all of the registers and protocol controlling elements of the BiSerial II design. Only the transceivers, and switches are external to the Xilinx device.

The PMC BiSerial-III is a part of the PMC Module family of modular I/O products. It meets the PMC and CMC draft Standards. In standard configuration, the PMC BiSerial-II is a Type 1 mechanical with low profile components on the back of the board and one slot wide, with 10 mm inter-board height. Contact Dynamic Engineering for a copy of this specification. It is assumed that the reader is at least casually familiar with this document and logic design.

The PCI interface to the host CPU is controlled by a logic block within the Xilinx. The BiSerial III design requires one wait state for read or write cycles to any address. The PMC BiSerial-III is capable of supporting 40 MBytes per second into and out of the DPR. With a Windows® read/write loop better than 20 Mb/sec is attained on most computers. The wait states refer to the number of clocks after the PCI core decode before the "terminate with data" state is reached. Two additional clock periods account for the 1 clock delay to decode the signals from the PCI bus and to convert the terminate with data state into the TRDY signal.

The BiSerial III can support many protocols. The PMC BiSerial-III-HW1 uses Manchester serial encoded data and clock. Data is sent in 16 bit words; concatenated for multiple word transfers. The Manchester timing is shown in the next diagram.

State machines within the FPGA control all transfers between the internal FIFO and FPGA logic, and the FPGA and the data buffers. The TX state machine reads from the transmit memory and loads the shift registers before sending the data. The RX state machine receives data from the data buffers and takes care of moving data from the shift register into the RX memory.

Data is read from the TX memory. The first two locations are control words. The control words are stored for state-machine use. The first data word is then read and loaded into the output shift register and the CRC generator. The Shift register is enabled to shift the data out. As the bits are shifted out of the shift register the data is encoded for Manchester compatibility. When the last data word has been loaded into the CRC and shift register, the hardware completes the CRC processing to be prepared for the last load to the shift register. Once the CRC has been transmitted the hardware checks to see if more data is to be sent or if this was the last packet in the message. There are several options including using a software CRC instead of the hardware generated one, adding a



postamble pattern etc. Please refer to the register bit definitions for more details.

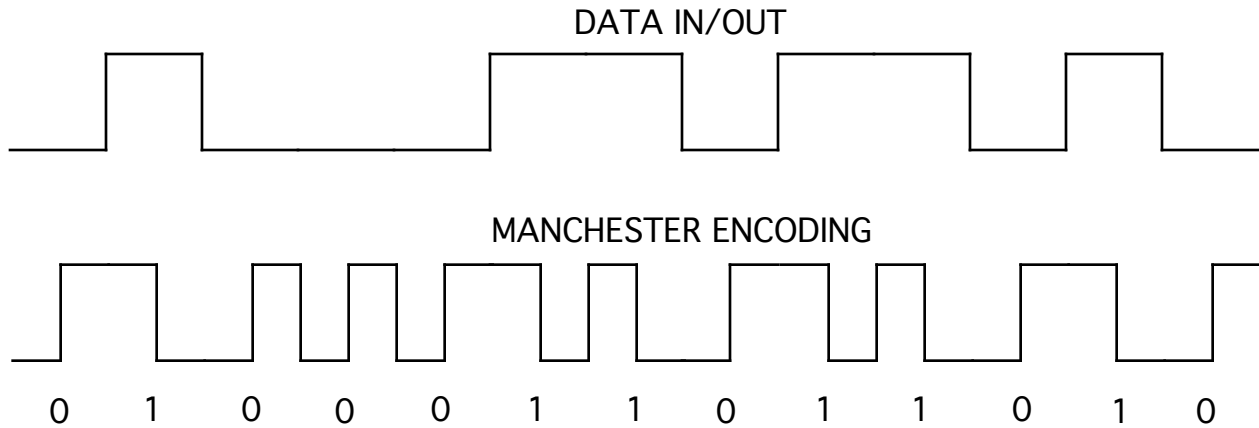

FIGURE 3 PMC BISERIAL III HW1 MANCHESTER TIMING DIAGRAM

The receive function uses a free running shift register coupled with the receive state-machine to capture the data. When the receiver detects the idle pattern followed by 4 Manchester '0's the receiver starts to capture data. The data is read in and stored into the DPR. The embedded length is used to determine where the CRC should be. The CRC is calculated as the data is received and checked against the CRC received with the packet. An error bit is set if the two do not match. Manchester errors within the packet are detected, and used to abort processing of the message. After a packet has been received the Post Amble is tested to see that it follows the proper protocol. The Manchester and Post Amble errors also set status bits.

This document is somewhat restricted as to the technical content allowed in describing the electrical interface. The document "Point-to-Point Data Bus Protocol Specification – C72-1199-069" provides a more complete description of the interface.

Address Map

BIS3_BASE	0x0000	0	base control register offset
BIS3_ID	0x0004	1	ID Register offset
BIS3_START_SET	0x0008	2	Start Register Set Bit offset
BIS3_START_CLR	0x000C	3	Start Register Clear Bit offset
BIS3_START_RDBK	0x0008	2	Start Register Read Back offset
BIS3_IO_DATA	0x0010	4	Data Register 31 - 0 with direct read-back
BIS3_IO_DIR	0x0014	5	Direction Reg 31 - 0 with direct read-back
BIS3_IO_TERM	0x0018	6	Termination Reg 31 - 0 with direct read-back
BIS3_IO_MUX	0x001C	6	MUX Register 31 - 0 with direct read-back
BIS3_IO_UCNTL	0x0020	8	Upper Control Reg 33 - 32 [data,dir, term, mux]
BIS3_STAT_FIFO	0x0024	9	FIFO and switch status Place Holder for future use
BIS3_PLL_CMD	0x0028	10	PLL control register and read-back of PLL data
BIS3_PLL_RDBK	0x002C	11	PLL control register read-back
BIS3_SM_CNTL_0	0x0040	16	chan 0 state-machine control read-write port
BIS3_SM_CNTL_1	0x0044	17	chan 1 state-machine control read-write port
BIS3_SM_CNTL_2	0x0048	18	chan 2 state-machine control read-write port
BIS3_SM_CNTL_3	0x004C	19	chan 3 state-machine control read-write port
BIS3_SM_CNTL_4	0x0050	20	chan 4 state-machine control read-write port
BIS3_SM_CNTL_5	0x0054	21	chan 5 state-machine control read-write port
BIS3_SM_CNTL_6	0x0058	22	chan 6 state-machine control read-write port
BIS3_SM_CNTL_7	0x005C	23	chan 7 state-machine control read-write port
BIS3_SM_CNTL_8	0x0060	24	chan 8 state-machine control read-write port
BIS3_SM_CNTL_9	0x0064	25	chan 9 state-machine control read-write port
BIS3_SM_CNTL_10	0x0068	26	chan 10 state-machine control read-write port
BIS3_SM_CNTL_11	0x006C	27	chan 11 state-machine control read-write port
BIS3_SM_CNTL_12	0x0070	28	chan 12 state-machine control read-write port
BIS3_SM_CNTL_13	0x0074	29	chan 13 state-machine control read-write port
BIS3_SM_CNTL_14	0x0078	30	chan 14 state-machine control read-write port
BIS3_SM_CNTL_15	0x007C	31	chan 15 state-machine control read-write port
BIS3_SM_CNTL_16	0x0080	32	chan 16 state-machine control read-write port
BIS3_SM_CNTL_17	0x0084	33	chan 17 state-machine control read-write port
BIS3_SM_CNTL_18	0x0088	34	chan 18 state-machine control read-write port
BIS3_SM_CNTL_19	0x008C	35	chan 19 state-machine control read-write port
BIS3_SM_CNTL_20	0x0090	36	chan 20 state-machine control read-write port
BIS3_SM_CNTL_21	0x0094	37	chan 21 state-machine control read-write port
BIS3_SM_CNTL_22	0x0098	38	chan 22 state-machine control read-write port
BIS3_SM_CNTL_23	0x009C	39	chan 23 state-machine control read-write port
BIS3_SM_CNTL_24	0x00A0	40	chan 24 state-machine control read-write port
BIS3_SM_CNTL_25	0x00A4	41	chan 25 state-machine control read-write port
BIS3_SM_CNTL_26	0x00A8	42	chan 26 state-machine control read-write port
BIS3_SM_CNTL_27	0x00AC	43	chan 27 state-machine control read-write port
BIS3_SM_CNTL_28	0x00B0	44	chan 28 state-machine control read-write port
BIS3_SM_CNTL_29	0x00B4	45	chan 29 state-machine control read-write port



BIS3_SM_CNTL_30	0x00B8	46	chan 30 state-machine control read-write port
BIS3_SM_CNTL_31	0x00BC	47	chan 31 state-machine control read-write port
BIS3_IO_RDBK	0x00C0	48	External IO read register
BIS3_IO_RDBKUPR	0x00C4	49	External IO read register UPPER data bits
BIS3_INT_STAT	0x00CC	51	Interrupt Status and clear register
BIS3_I20AR	0x00D4	53	I20 Address Storage register
BIS3_SM_mem_0	0x00800	ch 0	state-machine DPR read-write port 17-10 = 0x01
BIS3_SM_mem_1	0x01000	ch 1	state-machine DPR read-write port 17-10 = 0x02
BIS3_SM_mem_2	0x01800	ch 2	state-machine DPR read-write port 17-10 = 0x03
BIS3_SM_mem_3	0x02000	ch 3	state-machine DPR read-write port 17-10 = 0x04
BIS3_SM_mem_4	0x02800	ch 4	state-machine DPR read-write port 17-10 = 0x05
BIS3_SM_mem_5	0x03000	ch 5	state-machine DPR read-write port 17-10 = 0x06
BIS3_SM_mem_6	0x03800	ch 6	state-machine DPR read-write port 17-10 = 0x07
BIS3_SM_mem_7	0x04000	ch 7	state-machine DPR read-write port 17-10 = 0x08
BIS3_SM_mem_8	0x04800	ch 8	state-machine DPR read-write port 17-10 = 0x09
BIS3_SM_mem_9	0x05000	ch 9	state-machine DPR read-write port 17-10 = 0x0A
BIS3_SM_mem_10	0x05800	ch 10	state-machine DPR read-write port 17-10 = 0x0B
BIS3_SM_mem_11	0x06000	ch 11	state-machine DPR read-write port 17-10 = 0x0C
BIS3_SM_mem_12	0x06800	ch 12	state-machine DPR read-write port 17-10 = 0x0D
BIS3_SM_mem_13	0x07000	ch 13	state-machine DPR read-write port 17-10 = 0x0E
BIS3_SM_mem_14	0x07800	ch 14	state-machine DPR read-write port 17-10 = 0x0F
BIS3_SM_mem_15	0x08000	ch 15	state-machine DPR read-write port 17-10 = 0x10
BIS3_SM_mem_16	0x08800	ch 16	state-machine DPR read-write port 17-10 = 0x11
BIS3_SM_mem_17	0x09000	ch 17	state-machine DPR read-write port 17-10 = 0x12
BIS3_SM_mem_18	0x09800	ch 18	state-machine DPR read-write port 17-10 = 0x13
BIS3_SM_mem_19	0x0a000	ch 19	state-machine DPR read-write port 17-10 = 0x14
BIS3_SM_mem_20	0x0a800	ch 20	state-machine DPR read-write port 17-10 = 0x15
BIS3_SM_mem_21	0x0b000	ch 21	state-machine DPR read-write port 17-10 = 0x16
BIS3_SM_mem_22	0x0b800	ch 22	state-machine DPR read-write port 17-10 = 0x17
BIS3_SM_mem_23	0x0c000	ch 23	state-machine DPR read-write port 17-10 = 0x18
BIS3_SM_mem_24	0x0c800	ch 24	state-machine DPR read-write port 17-10 = 0x19
BIS3_SM_mem_25	0x0d000	ch 25	state-machine DPR read-write port 17-10 = 0x1A
BIS3_SM_mem_26	0x0d800	ch 26	state-machine DPR read-write port 17-10 = 0x1B
BIS3_SM_mem_27	0x0e000	ch 27	state-machine DPR read-write port 17-10 = 0x1C
BIS3_SM_mem_28	0x0e800	ch 28	state-machine DPR read-write port 17-10 = 0x1D
BIS3_SM_mem_29	0x0f000	ch 29	state-machine DPR read-write port 17-10 = 0x1E
BIS3_SM_mem_30	0x0f800	ch 30	state-machine DPR read-write port 17-10 = 0x1F
BIS3_SM_mem_31	0x10000	ch 31	state-machine DPR read-write port 17-10 = 0x20

FIGURE 4

PMC BISERIAL-III-HW1 INTERNAL ADDRESS MAP



The address map provided is for the local decoding performed within the PMC BiSerial-III. The addresses are all offsets from a base address, which is assigned by the system when the PCI bus is configured.

Programming

Programming the PMC BiSerial-III-HW1 requires only the ability to read and write data from the host. The base address is determined during system configuration of the PCI bus. The base address refers to the first user address for the slot in which the PMC is installed.

Depending on the software environment it may be necessary to set-up the system software with the PMC BiSerial-III "registration" data. For example in WindowsNT there is a system registry, which is used to identify the resident hardware.

In order to receive data the software is only required to enable the Rx channel and set the frequency parameters. To transmit the software will need to load the message into the appropriate channel Dual Port RAM, set the frequency and mode and enable the transmitter.

The interrupt service routine should be loaded and the interrupt mask set. The interrupt service routine can be configured to respond to the channel interrupts on an individual basis. After the interrupt is received, the data can be retrieved. An efficient loop can then be implemented to fetch the data. New messages can be received even as the current one is read from the Dual Port RAM.

The TX interrupt indicates to the software that a message has been sent and that the message has completed. If more than one interrupt is enabled, then the SW needs to read the status to see which source caused the interrupt. The status bits are latched, and are explicitly cleared by writing a one to the corresponding bit. It is a good idea to read the status register and write that value back to clear all the latched interrupt status bits before starting a transfer. This will insure that the interrupt status values read by the interrupt service routine came from the current transfer.

Refer to the Theory of Operation section above and the Interrupts section below for more information regarding the exact sequencing and interrupt definitions.

The VendorId = 0x10EE. The CardId = 0x0022. Current FLASH revision = 0x06



Register Definitions

BIS3_BASE

[\$00] BiSerial III Base Control Register Port read/write

Base CONTROL Register	
DATA BIT	DESCRIPTION
31-5	Spare
4	Reference Clock Select
3	I2O CLR
2	I2O EN
1	Interrupt Set
0	Interrupt Enable Master

FIGURE 5

PMC BISERIAL-III BASE CONTROL REGISTER BIT MAP

All bits are active high and are reset on power-up or reset command.

Interrupt Enable Master when '1' allows interrupts generated by the PMC-BiSerial-III-HW1 to be driven onto the carrier [INTA]. When '0' the interrupts can be individually enabled and used for status without driving the backplane. Polled operation can be performed in this mode.

Interrupt Set when '1' and the Master is enabled, forces an interrupt request. This feature is useful for testing and software development.

I2O EN when '1' allows the I2O interrupts to be activated. Interrupt requests are routed to the address stored in the I2O Address Register [I2OAR]. When '0' the I2O function is disabled.

I2O CLR when toggled high ['1'] will cause the current data stored in the I2O collection register to be cleared. It is recommended that the register clear bit be used immediately before enabling I2O operation to prevent previously stored events from causing interrupts.

Reference Clock Select when '1' selects the PLL clock A to be used as the DCM reference frequency. When '0' the on-board oscillator is used. The Oscillator is set to 40 Mhz. With a 40 MHz reference, the Hi Tx speed is 5 MHz and the Low Tx speed is 400 KHz. If the PLL is selected the ratio of reference to speed $[\div 8, \div 100]$ will be constant, and based on the new reference frequency.



BIS3_ID

[\$04] BiSerial III FLASH status/Driver Status Port read only

Design Number / FLASH Revision	
DATA BIT	DESCRIPTION
31-16	Design/Driver ID
15-0	FLASH revision

FIGURE 6

PMC BISERIAL-III INTERRUPT ENABLE REGISTER BIT MAP

The Design / Driver ID for the HW1 project is 0x0001. The FLASH ID will be updated as features are added or revisions made. See the programming section for the current FLASH revision.

BIS3_START_SET

BIS3_START_RDBK

[\$08] BiSerial III Start Set Control Register Port read/write

Start Set Register	
DATA BIT	DESCRIPTION
31-0	Channels to activate [write only]
31-0	Channels that are active [read only]

FIGURE 7

PMC BISERIAL-III START SET REGISTER

To start a channel, write a '1' to the corresponding bit. To clear a channel use the Start Clear register. Read back from this port reflects the channels which are active. Please note that TX channel "start" can be cleared by the channels state-machine.

BIS3_START_CLR

[\$OC] BiSerial III Start Clear Control Register Port write only

Start Clear Register	
DATA BIT	DESCRIPTION
31-0	Clear the active Start Bits

FIGURE 8

PMC BISERIAL-III START CLEAR REGISTER

Writing a '1' to a channel clear bit will cause that channels Start Bit to be cleared. The Channel will complete the current operation and then abort processing. Reading from the RDBK register will show the active channels. The state-machine may be running at a significantly slower rate than the PCI bus. There may be some delay in sensing that the start abort has been set for a particular channel.

The delay can be estimated to be the period of the clock in use and 12 periods. For Tx the clock rate is 2x the data rate. For Rx the clock rate is 8x the data rate. At low speed in Tx the delay would be $12 \times [1/800 \text{ Khz}] \Rightarrow 15 \text{ uS}$ or so. These are worst case delays.

Please note that the "ready_busy" bit can be used to check when an aborted channel is ready for a new start command. Please refer to the channel control registers.

BIS3_IO_DATA

[\$10] BiSerial III Parallel Data Output Register read/write

Parallel Data Output Register	
DATA BIT	DESCRIPTION
31-0	parallel output data

FIGURE 9 PMC BISERIAL-III PARALLEL OUTPUT DATA BIT MAP

There are 32 potential output bits in the parallel port. The Direction, Termination, and Mux Control registers are also involved. When the direction is set to output, and the Mux control set to parallel port the bit definitions from this register are driven onto the corresponding parallel port lines.

This port is direct read-write of the register. The IO side is read-back from the BIS3_IO_RDBK port. It is possible that the output data does not match the IO data in the case of the Direction bits being set to input or the Mux control set to state-machine.

BIS3_IO_DIR

[\$14] BiSerial III Direction Port read/write

Direction Control Port	
DATA BIT	DESCRIPTION
31-0	Parallel Port Direction Control bits

FIGURE 10 PMC BISERIAL-III DIRECTION CONTROL PORT

When set '1' the corresponding bit in the parallel port is a transmitter. When cleared '0' the corresponding bit is a receiver. The corresponding mux control bits must also be set to parallel port.

BIS3_IO_TERM

[\$18] BiSerial III Termination Port read/write

Direction Control Port	
DATA BIT	DESCRIPTION
31-0	Parallel Port Termination Control bits

FIGURE 11

PMC BISERIAL-III TERMINATION CONTROL PORT

When set '1' the corresponding bit is terminated. When cleared '0' the corresponding bit is not terminated. These bits are independent of the mux control definitions. When a bit is set to be terminated; the analog switch associated with that bit is closed to create a parallel termination of approximately 100 Ω . In most systems the receiving side is terminated, and the transmitting side is not. The drivers can handle termination on both ends.

BIS3_IO_MUX

[\$1C] BiSerial III Mux Port read/write

Direction Control Port	
DATA BIT	DESCRIPTION
31-0	Parallel Port Mux Control bits

FIGURE 12

PMC BISERIAL-III MUX CONTROL PORT

When set '1' the corresponding bit is set to State-Machine control. When cleared '0' the corresponding bit is set to parallel port operation. The Mux control definition along with the Data, Direction and Termination registers allows for a bit-by-bit selection of operation under software control.

BIS3_IO_UCNTL

[\$20] BiSerial III Upper Control Port read/write

Upper Bits Control Port	
DATA BIT	DESCRIPTION
25-24	Mux 33,32
17-16	Termination 33,32
9-8	Direction 33,32
1-0	Data 32,32

FIGURE 13

PMC BISERIAL-III UPPER CONTROL PORT

The BiSerial III has 34 transceivers. The upper control bits are concentrated within this register to cover the top 2 bits not controlled within the other control registers. The upper bits are only useable on the Bezel IO connector. Pn4 has only 64 connections and can't support the upper lines. The definitions are the same as the Data, Term, Dir and Mux port definitions for bit operation.

Data = Data transmitted when the Mux is set to '0' and the direction is set to '1'. Termination when set to '1' causes the parallel termination to be used. Setting the Mux control bits to '0' creates a parallel port for those bits. Setting the Mux control bits to '1' enables the state-machine to control the direction and data lines. The termination control is independent.

BIS3_IO_RDBK

[\$C0] BiSerial III IO Read-Back Port read only

IO Read-Back Port	
DATA BIT	DESCRIPTION
31-0	IO Data 31-0

FIGURE 14

PMC BISERIAL-III IO READBACK PORT

The IO lines can be read at any time. The value is not filtered in any way. If the transceivers are set to TX by the parallel port or state-machine then the read-back value will be the transmitted value. If the transceivers are set to receive then the port values will be those received by the transceivers from the external IO.

BIS3_IO_RDBKUPR

[\$C4] BiSerial III IO Upper Read-Back Port read only

IO Upper Read-Back Port	
DATA BIT	DESCRIPTION
1-0	IO Data 33-32

FIGURE 15

PMC BISERIAL-III IO READBACK PORT

The IO lines can be read at any time. The value is not filtered in any way. If the transceivers are set to TX by the parallel port or state-machine then the read-back value will be the transmitted value. If the transceivers are set to receive then the port values will be those received by the transceivers from the external IO. The upper bits are presented on this port.

BIS3_STAT_FIFO

[\$24] BiSerial III FIFO Status Port read only

FIFO Status & Switch Register	
DATA BIT	DESCRIPTION
23-16	sw7-0

FIGURE 16

PMC BISERIAL-III FIFO STATUS

The Switch Read Port has the user bits. The user bits are connected to the eight dip-switch positions. The switches allow custom configurations to be defined by the user and for the software to identify a particular board by its switch settings and to configure it accordingly.

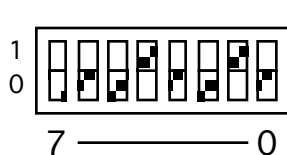

The Dip-switch is marked on the silk-screen with the positions of the digits and the '1' and '0' definitions. The numbers are hex coded. The example shown would produce 0x12 when read [and shifted down].

The rest of the FIFO Status port status bits are reserved for designs that require the use of external FIFOs.

BIS3_PLL_CMD, PLL_RDBK

[\$28, 2C] BiSerial III PLL Control

PLL Command Register, PLL CMD Read-back	
DATA BIT	DESCRIPTION
3	PLL Enable
2	PLL S2
1	PLL SCLK
0	PLL SDAT

FIGURE 17

PMC BISERIAL-III PLL CONTROL

The register bits for PLL Enable, PLL S2, PLL SCLK are unidirectional from the Xilinx to the PLL – always driven. SDAT is open drain. The SDAT register bit when written low and enabled will be reflected with a low on the SDAT signal to the PLL. When SDAT is taken high or disabled the SDAT signal will be tri-stated by the Xilinx, and can be driven by the PLL. The SDAT register bit when read reflects the state of the SDAT signal between the Xilinx and PLL and can be in a different state than the written SDAT bit. To read back the contents of the CMD port use the RDBK port.

PLL enable: When this bit is set to a one, SDAT is enabled. When set to '0' SDAT is tri-stated by the Xilinx.

PLL sclk/sdata output: These signals are used to program the PLL over the I2C serial interface. SCLK is always an output whereas sdata is bi-directional.

PLL s2 output: This is an additional control line to the PLL that can be used to select additional pre-programmed frequencies.

The PLL is a separate device controlled by the Xilinx. The PLL has a fairly complex programming requirement which is simplified by using the Cypress® frequency descriptor software, and then programming the resulting control words into the PLL using the PLL Control ports. The interface can be further simplified by using the Dynamic Engineering Driver to take care of the programming requirements.

BIS3_SM_CNTL31-0

[\$BC-40] BiSerial III State Machine Control Registers

State Machine Control Registers		
DATA	BIT	DESCRIPTION
	31	Ready_Busy [read only]
	30	Manchester Error Status / CLR
29-20		Address Pointer [read only]
	19	Post Amble Status / CLR
	18	CRC Error Status / CLR
	17-8	End of Message
	5	INTEN
	4	CLREN
	3	Bi_Uni
	2	IDLE Pattern Transmit
	1	HI_LOW Speed
	0	TX/RX Operation

FIGURE 18

PMC BISERIAL-III STATE MACHINE CONTROL REGISTERS

Each state-machine has a separate control register to govern the operation of the channel. In addition, the TX channels have control via the data in the Dual Port RAM associated with that channel.

TX/RX when set '1' indicates transmit operation. When cleared '0' indicates receiver operation.

HI_LOW when set '1' indicates operation at the "high speed" = 5 MHz nominal. In Low speed mode '0' the system operates at 400 Khz.

Bi_Uni when set '1' indicates that bidirectional operation is requested. When cleared '0' unidirectional operation is selected. In Bidirectional operation the memory is set to operate with the lower half allocated to TX and the upper half to RX. The counter will roll over to the correct boundaries [end of memory to 1/2, and 1/2 - 1 to start or end of memory to start] based on the mode of operation. Continuous operation is possible.

In BiDirectional mode the transmitter is only enabled when transmitting. When the transmission is completed the hardware automatically clears the TX bit and restarts in RX mode [BiDir only] without clearing the start bit. This allows a response, and wait for data without software intervention.

In Unidirectional mode the transmitter is enabled whenever there is data to send or the idle pattern is sent [if enabled]. The transmitter will send as many packets as the hardware is programmed to send, and at the end of the message clear the start bit. The hardware will remain in transmit or receive mode until



changed by software.

IDLE when '1' and in transmit mode commands the state-machine to insert the idle pattern when not sending data from the Dual Port RAM. In receive or BiDirectional mode this bit should be set to zero.. When in transmit mode, and this bit is cleared the transmitter is tri-stated between messages sent.

CLREN when set, and in transmit mode allows the start bit to be cleared at the end of a message sent. Note that the start bit is not cleared until the last packet of the message is sent. For Rx this bit has no effect.

Please note that in BiDirectional mode this bit should be set and the packet and end of message addresses should be the same to cause a single packet to be sent and the TX bit to be reset.

INTEN when set in RX or TX mode allows the channel to create an interrupt request. The INTEN signal is applied after the holding register and before the interrupt request to the PCI bus.

In TX mode there is a control bit in the DPR command that controls the interrupt to the packet level. In RX mode the interrupt is set for each packet received. In either case the interrupt is generated by the state machine, and captured by the interrupt holding register. By reading BIS3_INT_STAT the interrupt source(s) can be checked.

If **INTEN** is not set then the Interrupt status register can be used to poll for status. With individual INTEN bits each channel can be operated in polled or interrupt driven modes. To use the interrupt method the master interrupt enable must also be enabled.

End of Message is the address to test the address pointer against for the end of message. A message is a group of packets. The packet length is embedded in the message. Please refer to the Memory section for more details on the packet length control. As each packet is sent the hardware tests the end of message address to determine if there are more packets to send.

The end of packet address includes the command word through the CRC. Starting with '0' at the lower command word, and counting n 16 bit data words plus the CRC plus 1 = the end of packet address. When the end of message address matches the end of packet address the hardware recognizes that the last packet processing should occur. The command word is 32 bits and takes 2 locations. The offset [for post increment], label, length, and CRC take 1 each for a total of $6 - 1 = 5$ [count from zero] plus the data length. For a message with 8 locations the end of packet address would be "D".

The **Address Pointer** is stored when an interrupt condition happens during a read. The address location stored is the address on the State-machine side of



the Dual Port RAM. In receive mode an interrupt is generated each time a packet is received or a Manchester error is found. If the length is not incrementing to match the packet length received then a Manchester error has occurred cutting the packet short. The hardware will recover and look for the next packet. The address stored is the next address where data would be stored independent of LW boundaries. The next address used will be on a long word boundary. The value will be valid until the next interrupt condition occurs.

Manchester Error, CRC Error, Post Amble Error bit are set when the associated error is detected.

The **Manchester** error is set when an illegal Manchester encoding happens when properly coded data is expected. For example if a message is programmed to be of one length and a shorter length is received the Manchester bit will be set because the data will become the idle pattern [too wide bit periods] or fixed at 0 or 1.

The **CRC** error is set when the received CRC does not match the calculated CRC.

The **Post Amble** error is set when the Post Amble pattern is not detected at the end of a packet.

All three bits are cleared by writing with a '1' in the respective bit positions.

Ready_Busy when set indicates that the hardware is ready for a new start command. When cleared the hardware is executing a command. For example: in tx mode with the idle pattern turned on and unidirectional mode, the hardware will be ready while sending the idle pattern. The transmitter is active, but filling time and can accept a new start command. Once start is set, the hardware will begin transmission the status will change to Busy.

BIS3_INT_STAT

[\$CC] BiSerial III Interrupt Status and Clear Register

Interrupt Status and Clear Register	
DATA BIT	DESCRIPTION
31-0	Channel Interrupt or Clear bit

FIGURE 19

PMC BISERIAL-III INTERRUPT STATUS REGISTER

Each bit is set when an interrupt occurs on the associated channel. Each bit can be cleared by writing to the register with the same bit position set '1'. You do not need to rewrite with a '0' – the clearing action happens during the write.

This register is in parallel with the I2O interrupts. Usually only one or the other will be in use at a time. Both can be used if desired. Interrupt conditions are captured and processed in both places.

BIS3_I2OAR

[\$D4] BiSerial III I2O Address Register

I2O Address Register	
DATA BIT	DESCRIPTION
31-0	Address

FIGURE 20

PMC BISERIAL-III I2O ADDRESS REGISTER

The physical address where the I2O interrupt status should be written to is stored in this register. When active interrupts are detected the I2O sequence is started. The PCI bus is requested, the hardware waits for the grant and then writes the captured status to the stored address. Please note that this is the direct hardware address, and not an indirect [translated] address.

The active bits are auto cleared and the process re-enabled for new active interrupts. Interrupts that occur during an I2O cycle are stored until the hardware is re-enabled and cause a second immediate processing cycle. The receiving hardware must be able to handle multiple interrupt status writes in close succession. A FIFO is ideal for the receiving hardware implementation.

BIS3_SM_MEM31-0

[\$0x800 – 0x10000] BiSerial III Dual Port RAM address space

Each channel has Dual Port RAM [DPR] associated with it. The DPR is configured to have a 32 bit port on the PCI side and a 16 bit port on the IO side. Each DPR is 1K x 16 on the IO side and 512 x 32 on the PCI side.

When using BiDirectional mode the memory is further divided with an upper half and a lower half. The lower half is used for transmit and the upper half for receive data. The first 256 locations are used for TX and the upper 256 for receive in BiDirectional mode. In Unidirectional Mode the memory is all allocated to either RX or TX, and starts at offset 0x00.

The DPR is used to store the packet or packets of data to be transmitted or that have been received. When transmitting the data should be loaded prior to starting. It is possible to load additional data while transmitting if the software has tight control over the system timing.

In transmit the first 32 bits are the control word. The packet follows: Label, length, data, CRC. The CRC will normally be Set to 0x00 and the hardware instructed to create and insert the CRC.

Location IO	Value
0	lower command
1	upper command
2	label
3	length
4	First data
...	
N	last data
N+1	CRC or zero data

Location PCI	Value
0	upper lower command
1	length label
2	data 1 data 0
...	
N	CRC data last or data last data last -1 XXXX CRC

When the CRC falls on a non 32 bit boundary; the last location is padded, and the hardware will automatically skip that location to start on the new LW boundary.



The upper and lower command words are used to provide control on a packet-by-packet basis.

31	spare
30	Interrupt Enable
29	Post Amble Generation
28	CRC in Hardware
27-26	spare
25-16	spare
15-10	spare
9-0	End of Packet Address

The end of packet address and the end of message address are the word addresses on the IO side. The address is relative to the start of each DPR section – always starts at 0x00 and ends at 0x3ff for the 1K space.

The hardware will transmit until the end of packet address is detected. The hardware will then either stop or start a new packet based on the end of message address. The end of message address is not checked until the end of packet, and is checked as an absolute rather than a \geq to allow roll over addressing to be used.

At the end of the packet if the Interrupt Enable bit is set an interrupt request will be generated. Each packet can have a different setting for this bit. Once at the end of message, interrupt on every packet, alternate packets etc.

At the end of the packet the hardware can append the post amble as defined in the specification. If the bit is set the post amble will be added to the packet before going to tristate, or to the idle pattern if completed, or sending the next packet if more packets are queued. If the bit is not set the post amble is ignored and the next process started earlier.

If the CRC in hardware bit is set then the CRC is generated by the hardware and appended to the message. If the bit is not set then the CRC is loaded from the location in memory immediately following the data. In either case a CRC is sent. To create a CRC error on a given packet set the bit to “memory supplied” and provide a bogus CRC value for the data. With the per packet control one packet can be made bad and the rest good to test error detection and response. Due to the processing required the Hardware option will be the “normal” option.

Due to preprocessing and hardware timing constraints the address the hardware is working with leads the data currently being sent. The following example will help to define the End of packet and end of message address as well as the CRC processing.



```

i = 0x00;
*pmcbis3SM_mem_0 = 0x7000000d; // stop after 1 pkt enable interrupt,
post amble generation, crc hardware generation, 1 packet stopping at address d
i = 0x01;
*(pmcbis3SM_mem_0 + i) = 0x00080400; // length label 0008 0400
i = 0x02;
*(pmcbis3SM_mem_0 + i) = 0x5555aaaa; // data 2 data 1
i = 0x03;
*(pmcbis3SM_mem_0 + i) = 0x0000ffff; // data 4 data 3
i = 0x04;
*(pmcbis3SM_mem_0 + i) = 0xaaaa1234; // data 6 data 5
i = 0x05;
*(pmcbis3SM_mem_0 + i) = 0x5555aaaa; // data 8 data 7
i = 0x06;
*(pmcbis3SM_mem_0 + i) = 0x00000000; // XXXX CRC

```

The message length is 8. The length is the number of 16 bit words to be sent within the packet. The length does not include the command words, label, length or CRC – data 1->data 8 are included in the length.

The end of packet address does include everything including the command word. Starting with 0 at the lower command word and counting 16 bit words address 0x0d” is one past the CRC. In this case the End of Message is also set to address 0x0D [control register for channel]; so this would be a 1 packet case.

The CRC is calculated by a slightly non-standard process. The CRC is calculated on the message not including the CRC and the command words. The hardware has a parallel CRC calculation allowing each 16 bit word to be transmitted to be added to the CRC in one clock. At the end of the message having the CRC available to transmit in 1 clock is helpful in meeting the timing requirements of the transmission.

At the start of a packet the CRC is cleared. The bitwise [1’s complement] inversion of the label is then added. The length and data are added in without inversion. Then a word of 0x0000 is added. The remaining value is then transmitted immediately following the data. The hardware loads the CRC in parallel with the shift register used to transmit the data. The CRC is available one clock after the last data parallel load. The additional 0x0000 calculation is performed and then the data loaded at the appropriate transmit clock edge.

Using the example above the CRC is defined to be 0xDA8B.

The data from the shift register is then Manchester encoded and transmitted.

In the example the CRC falls onto a non long word boundary. The hardware will increment past the odd word and look for the next command on the next long word boundary. Please note that the memory locations are counting as long words – 0, 4, 8, C etc. The compiler will convert “i” to a long word count in the



example above. The next command will be located at the 8th long word.

When receiving the data is loaded into the DPR. There is no equivalent to the command word on the receive side. When doing loop-back testing the data will be offset in the receive channel compared to the transmit channel.

In Bidirectional mode the receive data is loaded starting from the half way point of the memory. In Unidirectional mode the receiver loads data starting at 0x00. Each packet is loaded starting on a long word boundary. If a packet ends on a non long word boundary one location is skipped.

In receive mode the receiver stays enabled until the software disables the receiver. In receive mode an interrupt request is generated on each packet received. The interrupt enable can be used to disable a channels interrupt request capabilities.

The Manchester decoder has some range of operation. The difference between the high and low speed mode is too great for the decoder to handle without selecting the proper speed of operation.

The receiver will look for a valid pre-amble before accepting data. When a valid pre-amble is found the data is captured and stored into the DPR. The CRC is calculated in hardware based on the data received and then compared against the CRC received with the message. If the CRC's do not match then the CRC error bit is set.

The receiver restarts by looking for a new pre-amble. The idle pattern or a tristated bus will be detected and not stored. When a new message is detected and received it will be stored starting at the next LW location. The messages will continue to increment up the memory. Eventually roll over causing part of the message to be written to low memory or high memory [depending on mode]. As long as the data has been read by the time the roll over occurs no data will be lost.

Messages are at least 4 words long with the label, length, 1 data word plus the CRC. At 5 MHz the minimum time between messages is 12.8 μ S [discounting the pre and postamble time]. An additional 3.2 μ S is added for each additional word in the message. The specification allows for up to 62 words. The hardware can handle longer messages than allowed for by the specification. The length field is 16 bits and the size of the memory is 1K.

The receiver uses the length embedded in the message to determine how much data to expect and when to expect the CRC to be received. The host software can read the length and determine the end address of the packet. The host software can also read the CRC status to determine if the message is valid. It is important that the host keep up with the hardware on an interrupt basis to make sure the CRC is checked for each message before the next packet is received.



Once set, the CRC stays set until explicitly cleared by the software. If the CRC is bad, and the host does not keep up then more than one message will have to be considered bad. The Manchester error and Post Amble error bits have the same restrictions. The three bits are located in the same register and can be checked in one operation.

Interrupts

PMC BiSerial-III interrupts are treated as auto-vectored. When the software enters into an exception handler to deal with a PMC BiSerial-III interrupt the software must read the status register to determine the cause(s) of the interrupt, clear the interrupt request(s) and process accordingly. Power on initialization will provide a cleared interrupt request and interrupts disabled.

For example, the PMC BiSerial-III Tx state machine(s) generates an interrupt request when a transmission is complete, and the Tx int enable and Master interrupt enable bits are set. The transmission is considered complete when the last bit is output from the output shift register.

The interrupt is mapped to INTA on the PMC connector, which is mapped to a system interrupt when the PCI bus configures. The source of the interrupt is obtained by reading BIS3_INT_STAT. The status remains valid until that bit in the status register is explicitly cleared.

When an interrupt occurs, the Master interrupt enable should be cleared, and the status register read to determine the cause of the interrupt. Next perform any processing needed to remove the interrupting condition, clear the latched bit and set the Master interrupt enable bit high again.

The individual enables operate after the interrupt holding latches, which store the interrupt conditions for the CPU. This allows for operating in polled mode simply by monitoring the BIS3_INT_STAT register. If one of the enabled conditions occurs, the interrupt status bit will be set, but unless the Master interrupt, and the channel interrupt enable is set, a system interrupt will not occur.

I2O interrupts are also available. Program the Address where the interrupt status should be written to in the I2OAR, Clear any stored interrupts in the IU2O register, and then program the I2O enable to be set. The hardware will collect interrupt conditions, and write them to the address stored in the I2OAR. The interrupts will still need to be processed at the hardware level.

Loop-back

The Engineering kit has reference software, which includes an external loop-back test. The HW1 version of the PMC-BiSerial III utilizes a 68 pin SCSI II front panel connector. The test requires an external cable with the following pins connected.

SIGNALs	+	-	+	-
Ch 0,1	1	35	2	36
Ch 2,3	3	37	4	38
Ch 4,5	5	39	6	40
Ch 6,7	7	41	8	42
Ch 8,9	9	43	10	44
Ch 10,11	11	45	12	46
Ch 12,13	13	47	14	48
Ch 14,15	15	49	16	50
Ch 16,17	17	51	18	52
Ch 18,19	19	53	20	54
Ch 20,21	21	55	22	56
Ch 22,23	23	57	24	58
Ch 24,25	25	59	26	60
Ch 26,27	27	61	28	62
Ch 28,29	29	63	30	64
Ch 30,31	31	65	32	66

Additional Channels used for parallel Port

Ch 32,33	33	67	34	68
----------	----	----	----	----

PMC PCI Pn1 Interface Pin Assignment

The figure below gives the pin assignments for the PMC Module PCI Pn1 Interface on the PMC BiSerial-III. See the User Manual for your carrier board for more information. Unused pins may be assigned by the specification and not needed by this design.

GND	-12V[unused]	1	2
	INTA#	3	4
		5	6
BUSMODE1#	+5V	7	8
		9	10
GND -		11	12
CLK	GND	13	14
GND -		15	16
	+5V	17	18
	AD31	19	20
AD28-	AD27	21	22
AD25-	GND	23	24
GND -	C/BE3#	25	26
AD22-	AD21	27	28
AD19	+5V	29	30
	AD17	31	32
FRAME#-	GND	33	34
GND	IRDY#	35	36
DEVSEL#	+5V	37	38
GND	LOCK#	39	40
		41	42
PAR	GND	43	44
	AD15	45	46
AD12-	AD11	47	48
AD9-	+5V	49	50
GND -	C/BE0#	51	52
AD6-	AD5	53	54
AD4	GND	55	56
	AD3	57	58
AD2-	AD1	59	60
	+5V	61	62
GND		63	64

FIGURE 21

PMC BISERIAL-III PN1 INTERFACE

PMC PCI Pn2 Interface Pin Assignment

The figure below gives the pin assignments for the PMC Module PCI Pn2 Interface on the PMC BiSerial-III. See the User Manual for your carrier board for more information. Unused pins may be assigned by the specification and not needed by this design.

+12V[unused]		1	2
		3	4
GND	GND	5	6
		7	8
		9	10
RST#	BUSMODE3#	11	12
	BUSMODE4#	13	14
	GND	15	16
AD30	AD29	17	18
GND	AD26	19	20
AD24		21	22
IDSEL	AD23	23	24
	AD20	25	26
AD18		27	28
AD16	C/BE2#	29	30
GND		31	32
TRDY#		33	34
GND	STOP#	35	36
PERR#	GND	37	38
	SERR#	39	40
C/BE1#	GND	41	42
AD14	AD13	43	44
GND	AD10	45	46
AD8		47	48
AD7		49	50
		51	52
	GND	53	54
		55	56
GND		57	58
		59	60
		61	62
GND		63	64

FIGURE 22

PMC BISERIAL-III PN2 INTERFACE

BiSerial III Front Panel IO Pin Assignment

The figure below gives the pin assignments for the PMC Module IO Interface on the PMC BiSerial-III. Also, see the User Manual for your carrier board for more information. For customized version, or other options, contact Dynamic Engineering.

IO_0p	IO_0m	1	35
IO_1p	IO_1m	2	36
IO_2p	IO_2m	3	37
IO_3p	IO_3m	4	38
IO_4p	IO_4m	5	39
IO_5p	IO_5m	6	40
IO_6p	IO_6m	7	41
IO_7p	IO_7m	8	42
IO_8p	IO_8m	9	43
IO_9p	IO_9m	10	44
IO_10p	IO_10m	11	45
IO_11p	IO_11m	12	46
IO_12p	IO_12m	13	47
IO_13p	IO_13m	14	48
IO_14p	IO_14m	15	49
IO_15p	IO_15m	16	50
IO_16p	IO_16m	17	51
IO_17p	IO_17m	18	52
IO_18p	IO_18m	19	53
IO_19p	IO_19m	20	54
IO_20p	IO_20m	21	55
IO_21p	IO_21m	22	56
IO_22p	IO_22m	23	57
IO_23p	IO_23m	24	58
IO_24p	IO_24m	25	59
IO_25p	IO_25m	26	60
IO_26p	IO_26m	27	61
IO_27p	IO_27m	28	62
IO_28p	IO_28m	29	63
IO_29p	IO_29m	30	64
IO_30p	IO_30m	31	65
IO_31p	IO_31m	32	66
IO_32p	IO_32m	33	67
IO_33p	IO_33m	34	68

FIGURE 23

PMC BISERIAL-III FRONT PANEL INTERFACE

Applications Guide

Interfacing

The pin-out tables are displayed with the pins in the same relative order as the actual connectors. The pin definitions are defined with noise immunity in mind. The pairs are chosen to match standard SCSI II/III cable pairing to allow a low cost commercial cable to be used for the interface.

Some general interfacing guidelines are presented below. Do not hesitate to contact the factory if you need more assistance.

Watch the system grounds. All electrically connected equipment should have a fail-safe common ground that is large enough to handle all current loads without affecting noise immunity. Power supplies and power-consuming loads should all have their own ground wires back to a common point.

Power all system power supplies from one switch. Connecting external voltage to the PMC BiSerial-III when it is not powered can damage it, as well as the rest of the host system. This problem may be avoided by turning all power supplies on and off at the same time. Alternatively, the use of OPTO-22 isolation panels is recommended.

Keep cables short. Flat cables, even with alternate ground lines, are not suitable for long distances. The PMC BiSerial-III does not contain special input protection. The connector is pinned out for a standard SCSI II/III cable to be used. The twisted pairs are defined to match up with the BiSerial III pin definitions. It is suggested that this standard cable be used for most of the cable run.

Terminal Block. We offer a high quality 68-screw terminal block that directly connects to the SCSI II/III cable. The terminal block can mount on standard DIN rails. HDEterm68
[<http://www.dyneng.com/HDEterm68.html>]

We provide the components. You provide the system. Safety and reliability can be achieved only by careful planning and practice. Inputs can be damaged by static discharge, or by applying voltage outside of the RS-485 devices rated voltages.



Construction and Reliability

PMC Modules are conceived and engineered for rugged industrial environments. The PMC BiSerial-III is constructed out of 0.062 inch thick High Temp FR4 material. The PC Boards are ROHS compliant. Dynamic Engineering has selected gold immersion processing to provide superior performance, and reliability. [not be subject to tin whisker issues].

Through hole and surface mounting of components are used. IC sockets use screw machine pins. High insertion and removal forces are required, which assists in the retention of components. If the application requires unusually high reliability or is in an environment subject to high vibration, the user may solder the corner pins of each socketed IC into the socket, using a grounded soldering iron.

The PMC connectors are rated at 1 Amp per pin, 100 insertion cycles minimum. These connectors make consistent, correct insertion easy and reliable.

The PMC is secured against the carrier with four screws attached to the 2 stand-offs and 2 locations on the front panel. The four screws provide significant protection against shock, vibration, and incomplete insertion.

The PMC Module provides a low temperature coefficient of 2.17 W/°C for uniform heat. This is based upon the temperature coefficient of the base FR4 material of 0.31 W/m-°C, and taking into account the thickness and area of the PMC. The coefficient means that if 2.17 Watts are applied uniformly on the component side, then the temperature difference between the component side and solder side is one degree Celsius.

Thermal Considerations

The BiSerial III design consists of CMOS circuits. The power dissipation due to internal circuitry is very low. It is possible to create a higher power dissipation with the externally connected logic. If more than one Watt is required to be dissipated due to external loading then forced air cooling is recommended. With the one degree differential temperature to the solder side of the board external cooling is easily accomplished.



Warranty and Repair

Please refer to the warranty page on our website for the current warranty offered and options.

<http://www.dyneng.com/warranty.html>

Service Policy

Before returning a product for repair, verify as well as possible that the suspected unit is at fault. Then call the Customer Service Department for a RETURN MATERIAL AUTHORIZATION (RMA) number. Carefully package the unit, in the original shipping carton if this is available, and ship prepaid and insured with the RMA number clearly written on the outside of the package. Include a return address and the telephone number of a technical contact. For out-of-warranty repairs, a purchase order for repair charges must accompany the return. Dynamic Engineering will not be responsible for damages due to improper packaging of returned items. For service on Dynamic Engineering Products not purchased directly from Dynamic Engineering, contact your reseller. Products returned to Dynamic Engineering for repair by other than the original customer will be treated as out-of-warranty.

Out of Warranty Repairs

Out of warranty repairs will be billed on a material and labor basis. The current minimum repair charge is \$100. Customer approval will be obtained before repairing any item if the repair charges will exceed one half of the quantity one list price for that unit. Return transportation and insurance will be billed as part of the repair and is in addition to the minimum charge.

For Service Contact:

Customer Service Department
Dynamic Engineering
435 Park Dr.
Ben Lomond, CA 95005
831-336-8891
831-336-3840 fax

support@dyneng.com



Specifications

Host Interface:	[PMC] PCI Mezzanine Card - 32 bit, 33 MHz
Serial Interface:	32 manchester encoded serial interfaces. 16 bit word size, MSB first, multiple words, CRC, embedded length, label
Tx Data rates generated:	40 MHz oscillator used to generate 80 MHz. 800 Khz, 3.2 MHz, 10 MHz and 40 Mhz are generated to provide TX and RX reference rates. 5 MHz and 400 KHz IO frequencies supported via software selection. PLL for custom frequencies supplied.
Tx Options	Tristate or transmit IDLE pattern between messages, append postamble pattern, calculate and append CRC in hardware, interrupt on a packet basis.
Rx Data rates accepted:	Continuous at 5 MHz. or 400 KHz software programmable
Software Interface:	Control Registers, Status Ports, Dual Port RAM, Driver Available
Initialization:	Hardware Reset forces all registers to 0.
Access Modes:	LW boundary Space (see memory map)
Wait States:	1 for all addresses
Interrupt:	Tx interrupt at end of packet transmission Rx interrupt at end of packet reception Software interrupt I2O interrupts
DMA:	No DMA Support implemented at this time
Onboard Options:	All Options are Software Programmable
Interface Options:	68 pin twisted pair cable 68 screw terminal block interface
Dimensions:	Standard Single PMC Module.
Construction:	FR4 Multi-Layer Printed Circuit, Through Hole and Surface Mount Components. Programmable parts are socketed.
Temperature Coefficient:	2.17 W/°C for uniform heat across PMC
Power:	Max. TBD mA @ 5V
Temperature range	0-70 standard, Extended Temperature available [-40 + 85]



Order Information

PMC BiSerial-III-HW1	PMC Module with 32 serial channels, 34 bit parallel port [overlaps with serial channels] RS-485 IO. 32 bit data interface
Eng Kit-PMC BiSerial-III	HDeterm68 - 68 position screw terminal adapter http://www.dyneng.com/HDeterm68.html HDEcabl68 - 68 IO twisted pair cable http://www.dyneng.com/HDEcabl68.html Technical Documentation, 1. PMC BiSerial-III Schematic 2. PMC BiSerial-III-HW1 Driver software and user application. Data sheet reprints are available from the manufacturer's web site

Note: The Engineering Kit is strongly recommended for first time PMC BiSerial-III purchases.

Schematics

Schematics are provided as part of the engineering kit for customer *reference only*. This information was current at the time the printed circuit board was last revised. This revision letter is shown on the front of this manual as "Corresponding Hardware Revision." This information is not necessarily current or complete manufacturing data, nor is it part of the product specification.

All information provided is Copyright Dynamic Engineering

